



ISSN: 0975-833X

Available online at <http://www.journalcra.com>

*International Journal of Current Research*  
Vol. 15, Issue, 03, pp.24199-24205, March, 2023  
DOI: <https://doi.org/10.24941/ijcr.44960.03.2023>

**INTERNATIONAL JOURNAL  
OF CURRENT RESEARCH**

## RESEARCH ARTICLE

# ARCHITECTURAL HERITAGE MANAGEMENT AT LOCAL LEVEL IN THE KINGDOM OF SAUDI ARABIA

**\*Ghazy Abdullah Albaqawy**

Architectural Engineering Department, College of Engineering, University of Hail, Ha'il, Saudi Arabia

### ARTICLE INFO

#### Article History:

Received 27<sup>th</sup> December, 2022  
Received in revised form  
09<sup>th</sup> January, 2023  
Accepted 15<sup>th</sup> February, 2023  
Published online 30<sup>th</sup> March, 2023

#### Key words:

Architectural Heritage, Organizational Structures, Saudi Context.

#### \*Corresponding Author:

*Vitalis Goodwell Chipfakacha*

Copyright©2023, Ghazy Abdullah Albaqawy. This is an open access article distributed under the Creative Commons Attribution License, which permits unrestricted use, distribution, and reproduction in any medium, provided the original work is properly cited.

Citation: Ghazy Abdullah Albaqawy. 2023. "Architectural Heritage Management at Local Level in the Kingdom of Saudi Arabia". *International Journal of Current Research*, 15, (03), 24199-24205

### ABSTRACT

This study aims to investigate the current Saudi cultural heritage management system, including the involvement of participant from various stockholders such as municipalities, tourism, and education. The importance of effective management in implementing laws and regulations is highlighted, particularly in the development of heritage sites. To improve the organizational structure for cultural heritage, the paper addresses the issue of connecting national and local levels and enhancing the contribution of stakeholders through public awareness campaigns. The discussion also emphasizes the need to strengthen connections between key players and improve the management of heritage sites in the tourism, architectural, and urban sectors.

## INTRODUCTION

Architectural heritage management at the local level is a crucial aspect of preserving the historical and cultural significance of built structures in a community. The local level management focuses on conserving buildings, monuments, and other structures that hold historic and cultural value. This management involves various stakeholders, including government agencies, private entities, and community members. Effective management of architectural heritage at the local level is critical to ensure sustainable preservation and utilization of these structures. The process of decision-making, understanding of the local context, and balancing the interests of all stakeholders are significant factors that determine the success of architectural heritage management at the local level. In this context, this field has garnered attention from scholars and policymakers globally, and several best practices have emerged. Many countries have different national and municipal government systems, especially in terms of power dynamics, administration, and policymaking (Orbasli, 2000). In Kingdom of Saudi Arabia, the highest level of the organizational hierarchy is occupied by the Council of Ministers, which is comprised of all ministries, including 26 ministries, 33 ministers, and various sub-ministerial bodies like commissions and agencies. The objective is not to debate alternative political forms, but rather to comprehend the power dynamics and connections among important decision-makers in Saudi Arabia. Conflict and tension can arise in the relationships between decision-makers, particularly when there are disparities between the objectives and priorities of local and national organizations. Recognising these conflicts is crucial, as emphasized by the Royal Town Planning Institute in 2001 and

Flyvbjerg & Richardson (2002). Researchers like Larkham ((1990) have highlighted the importance of the management process, particularly with regards to understanding the local context and the role of insiders and outsiders. To achieve effective and sustainable management, there needs to be an equilibrium between outsiders and insiders, both vertically and horizontally, at both the local and national stages. The government structure and power hierarchy in Saudi Arabia play a crucial role in decision-making processes. In terms of heritage management, including urban and architectural heritage, numerous players are involved, creating a complex network of relationships that can lead to conflict and tension. The Saudi Commission for Tourism and National Heritage (SCTH) is responsible for the management and preservation of cultural and historical sites. However, the SCTH works in collaboration with other entities such as municipalities, private investors, and local communities to ensure the effective management of architectural heritage. Understanding and identifying these conflicts is essential for effective planning and management. A collaborative approach between all stakeholders and an equilibrium between insiders and outsiders are necessary for effective management. The aim of this paper is to gain an understanding of the existing mechanisms for managing cultural patrimony. The focus is on identifying opportunities for enhancing the organizational framework for cultural heritage management, particularly in the context of tourism, as well as with regard to architectural and urban heritage.

**Saudi Heritage Management:** The protection of heritage and the environment is essential for sustainable tourism, and governments have a crucial role to play in this regard (Paszucha, 1995). However, preservation of cultural heritage should not be limited to just

protecting monuments as evidence of the past, but also to ensure that the social and cultural factors that shape these spaces are taken into consideration (ICOMOS, 2013). However, cultural heritage should not be regarded solely as physical evidence of the past, but also as spaces that continue to shape social and cultural aspects, as noted by ICOMOS (2013). Organizations dedicated to preserving antiquities and cultural heritage have developed in certain nations out of an absence of appreciation for the importance of cultural patrimony and legacy patriotism, as discussed by Barakat & Daher (2000). Therefore, it is important to ensure that heritage management and conservation take into account the cultural and social values of the heritage and the local community, in addition to their physical significance. This approach can contribute to sustainable tourism and cultural preservation. The creation of the Saudi Commission for Tourism (SCT) in 2000 was a significant step towards managing heritage, particularly with the merger of antiquities and museums with SCTA in 2008. For a long time, cultural heritage was not officially managed, which resulted in a lack of public awareness and organizational understanding. The Ministry of Culture and Information (MOCI) made some efforts to promote intangible heritage, specifically folklore, whereas antiquities were in charge of the Ministry of Education (MOE). However, it is necessary to examine how heritage, whether tangible or intangible, is placed within the Saudi government's organizational structure, particularly with regard to the diminishing intangible heritage in folklore or other apparent activities.

There is an absence of consciousness regarding the values of cultural heritage in some Saudi context, which results in a lack of clarity regarding the position of heritage among key stakeholders. Given the abundance of cultural heritage in the region, it is important to prioritize maintenance efforts and to ensure that cultural heritage is understood and valued in its proper context.

**Key Players:** Understanding the major participants involved in managing heritage in Saudi Arabia is essential in identifying potential causes of tension and conflict. Various governmental and non-governmental organizations operating at local and national levels play significant roles in heritage site management, particularly those focused on socio-cultural issues. In addition, a multitude of different departments and sections may be involved in managing both tangible and intangible patrimony. However, this paper focuses on the organizations that have a direct impact on cultural heritage, particularly historical structures, as they have an essential role in the overall management of heritage. The incorporation and conflict between main players at the national scale can impact the regional level, specifically heritage sites. The key players responsible for this in Saudi Arabia are the education, municipal, culture, and tourism sectors. These sectors have both direct and indirect impacts on heritage sites.

**Municipal Sector:** The municipality was founded in 1926 and became an autonomous entity in 1975. The Ministry of Municipal and Rural Affairs (MOMRA) has authority over physical areas, particularly those situated within urban, suburban, and rural limits. Consequently, MOMRA is responsible for the majority of public heritage sites, except for those that were transferred from the Department of Archaeology and Museums at the Ministry of Education to the Saudi Commission for Tourism and National Heritage (SCTNH) following their merger in 2008. The management of cultural patrimony is heavily influenced by MOMRA, which holds significant responsibility and power. However, the level of contribution and involvement in heritage management within MOMRA can vary (Figure 1). Specifically, the Deputy Ministry for Planning is a key player in the organisation of heritage sites, as it is responsible for making decisions and overseeing the implementation of related steps. In Saudi Arabia, the local level is comprised of a municipality for each province, which is linked to sub-municipalities for each city, town, and county (Figure 2). The principal municipality is important not just on a local level, but also on a national level. MOMRA sub-municipalities can benefit from increased municipality awareness and understanding.

This applies not just to awareness, but also to the site's laws and policies. Essentially, feedback, obstacles, problems, and financial issues arise from the main municipality, which provides an opportunity to enhance the improvement of heritage sites. The sub-municipalities are principally in charge of activities like licensing, cleaning, and monitoring. There is a necessity to enhance the knowledge and involvement of both the top-down and bottom-up methods in the municipalities and sub-municipalities across regions and cities.

**The Education Sector:** Prior to 1972, there was no official establishment responsible for managing cultural patrimony in Saudi Arabia, particularly architectural heritage. It is important to recognize the major historical eras and key stakeholders involved in heritage management, as depicted in (Figure 3 and 4). Antiquities were the main focus of heritage management in 1972, and this continued until 2014. During this period, the MOE was responsible for managing antiquities, with the exception of a few initiatives and regulations implemented in the 1980s by MOMRA. These stages primarily represent the implementation of laws and policies that resulted in the development of the organizational structure (Albaqawy, 2019). There was a lack of progress not only in terms of rules and regulations but also in communities and heritage. Two different methods towards heritage emerged. The first approach viewed heritage, especially architectural heritage, as old structures located on valued land. This opinion was held mostly by those in authority in municipalities, causing conflict and hindering the improvement of cultural heritage understanding, particularly in architecture. However, after 2014, SCTNH intervened to address these conflicts, particularly through implementing laws and regulations. The second approach to heritage regarded it from an archaeological perspective, with individuals from the division of antiquities and archaeology, seeing heritage as part of antiquities that need to be protected.

SCTNH had a significant effect on the understanding of cultural heritage by emphasizing the connection between heritage and tourism. This association between heritage and tourism, particularly in terms of architectural patrimony, has influenced the perception of cultural heritage. Furthermore, this connection has affected cultural heritage, particularly due to the seasonal of tourism and the manner in which these initiatives have been implemented. The cultural heritage, which was managed by the MOE, was mainly influenced by the value of antiquities while other cultural heritage values received less attention. This lack of consideration was partly due to limitations in the law (Albaqawy, 2019) and resulted in a focus on excavations and interpretation of antiquities with less emphasis on other standards and contexts. As a consequence, archaeology became the dominant aspect of heritage management, with little attention given to tangible and intangible heritage. Additionally, public awareness of cultural heritage was affected by the education system, and the MOE's general department mainly focused on antiquities with less emphasis on other heritage values (Abdulhamid, 2012; AbdulRahman 1982). The Deputy Ministry in charge of Curricula and Educational Programs is a significant player within MOE as it is responsible for incorporating cultural heritage values, setting and consciousness into the education system. Meanwhile, the Deputy Ministry of Buildings plays a vital role in presenting vernacular architecture and local character in school design. The General Department of Education (GDE) and Department of Education (DE) (Figure 5) act as the intermediary between the decision makers at the ministry and the end users at schools. The local level players within GDE hold significant importance in the national level. Despite this, national-level actions are taken, while the local level is responsible for implementing and monitoring the execution of these actions. The daily responsibilities of educators and administrators distract them from cultural heritage, and the leaders at the national level have overlooked the incorporation of cultural heritage in their planning. As a result, local authorities have no authority to address cultural heritage issues and are solely focused on the curriculum. Therefore, it is necessary to clarify the link between the GDE at the local and national levels.

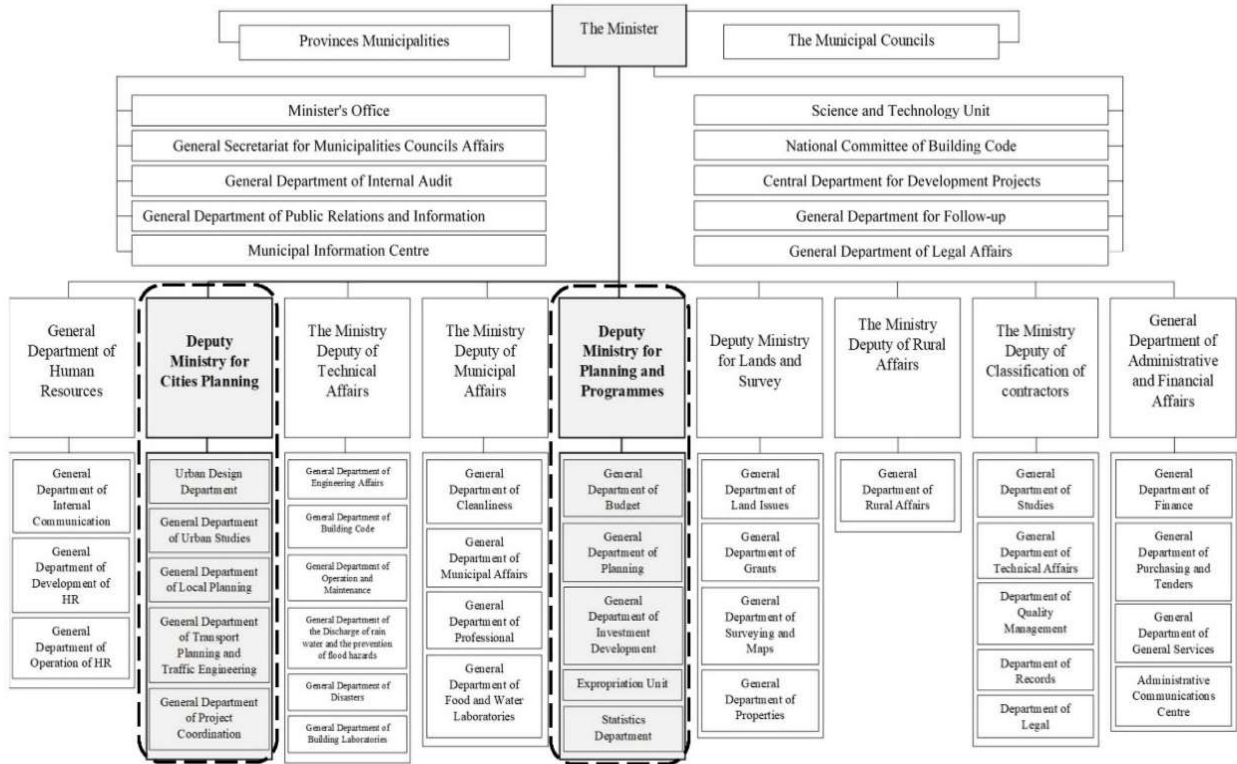

Figure 1. The two primary players within the organizational structure of MOMRA (MOMRA, 2018)

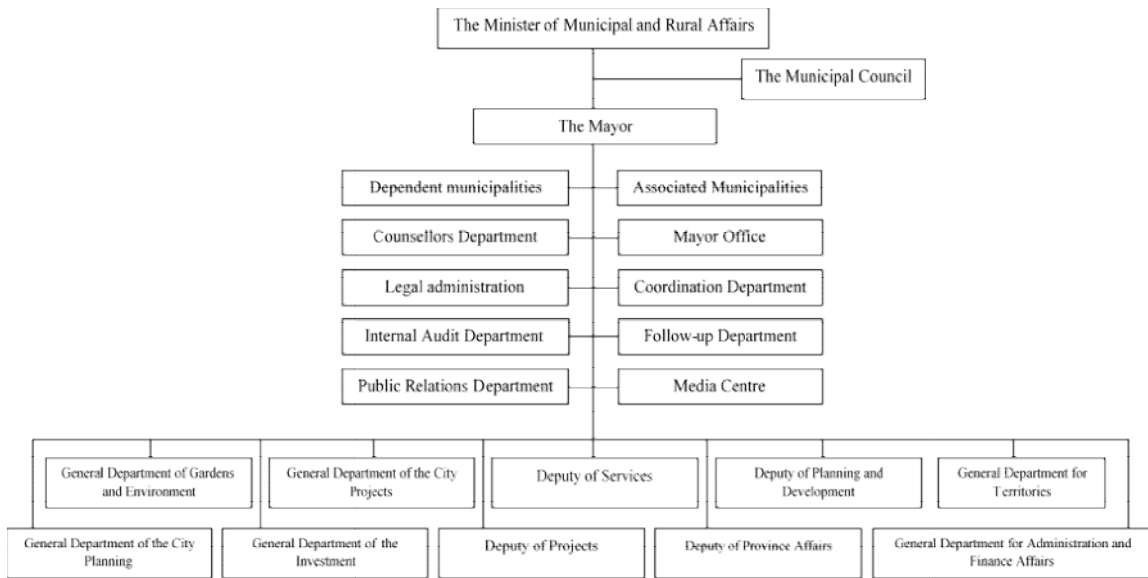

Figure 2. The organizational hierarchy for local municipalities (first, second and third levels) (MOMRA, 2018)

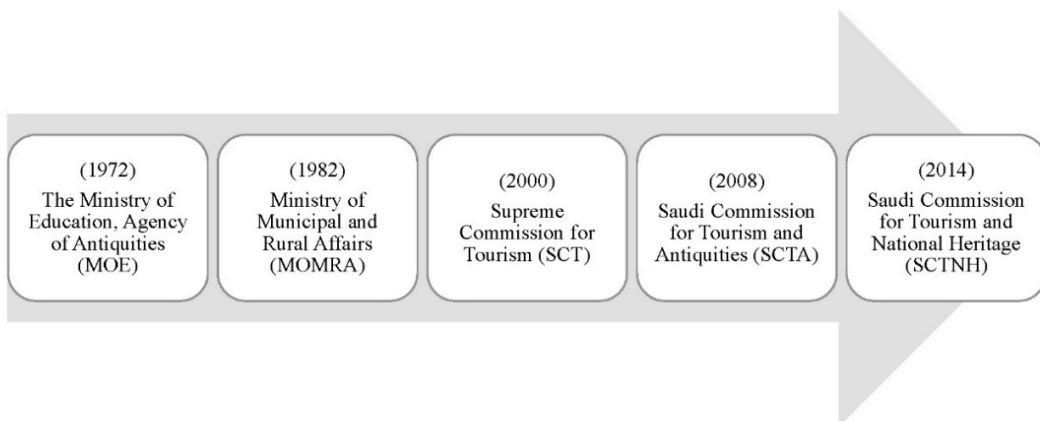

Figure 3. The main five periods of heritage management in KSA

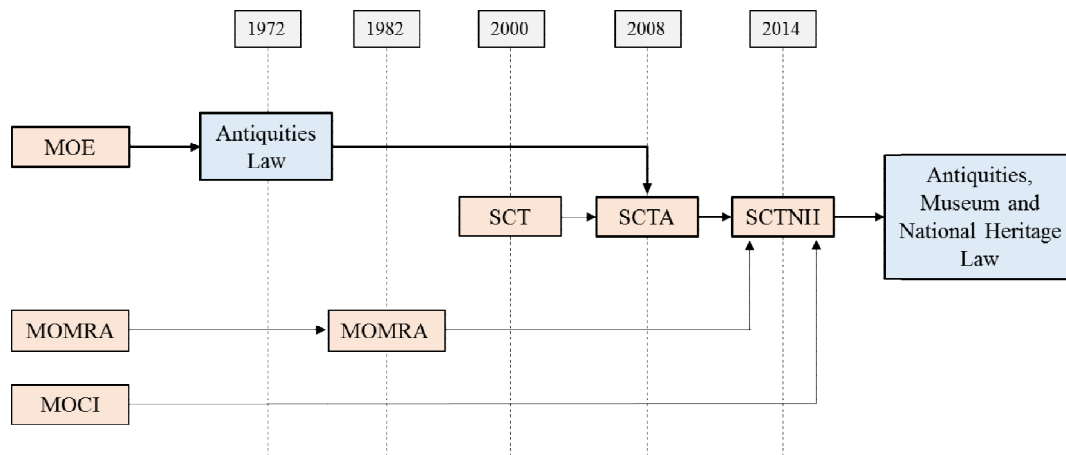

Figure 4. The heritage development main players which led by MOE in KSA

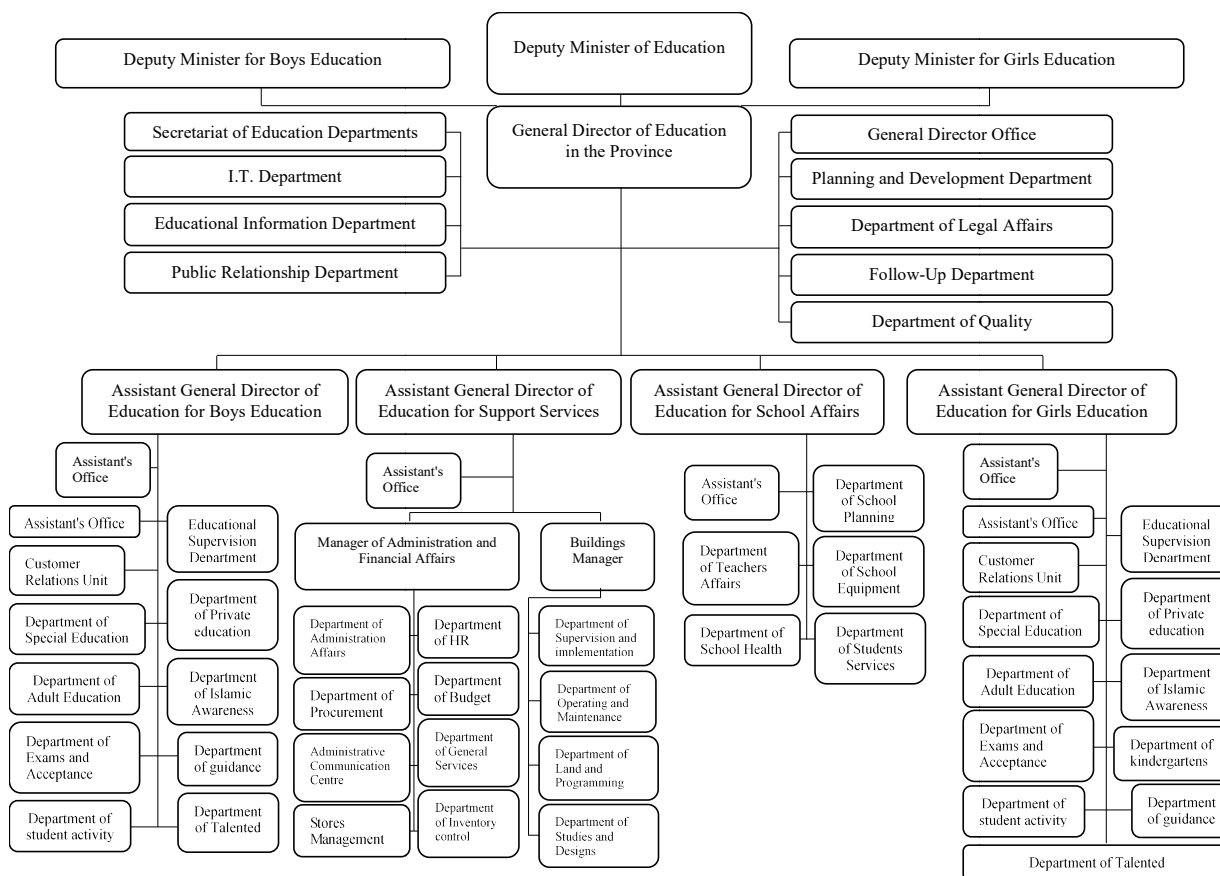

Figure 5. The GDE structure at local level

**Tourism Sector:** Saudi Arabia's architectural heritage is predominantly located in historical town centres, making them important cultural assets. Cultural heritage offers a wide variety of social and economic advantages, and can attract visitors for tourism, leisure, and entertainment. Tourism based on cultural heritage has the ability to support economic growth and revitalize historic cities while preserving their cultural values in their original context. Therefore, cultural tourism can be used both as a means and an end in the improvement and organisation of cultural heritage. According to Ashworth and Tunbridge (2000), the 3 key components that must be considered are the activity of tourism, the resources of heritage, and the setting of the city. The balance between these elements varies between sites, but they are all essential to justify tourism to heritage sites. Prior to 2000, local tourism in Saudi Arabia did not focus on heritage, except in a few select locations. The establishment of the Saudi Commission for Tourism (SCT) in 2000 aimed to change this by promoting tourism as an important economic revenue. The SCT created a General Strategy for Tourism, which outlined its vision and

mission of developing sustainable tourism for economic, environmental, and cultural benefits (SCT, 2003:8-9). Although the SCTNH is one of Saudi Arabia's most active government agencies (Figure 6), its classification as a general authority rather than a ministry has limited its power and budgetary authority. As a result, the SCTNH has had to devote more time to improving other organizations rather than focusing on its main mission of fostering cultural heritage. Despite these challenges, the SCTNH has made significant efforts, such as establishing cooperation agreements with stakeholders and creating tourism development committees.

**Culture and media Sector:** Before the establishment of The Ministry of Culture (MOC), The Ministry of Culture and Information (MOCI) was responsible for managing and preserving intangible cultural heritage, including folklore, literary clubs, and other cultural events. In addition, it has a significant impact on shaping public opinion through its management of TV and radio programmes. Within the MOCI, there are several key departments that focus on cultural

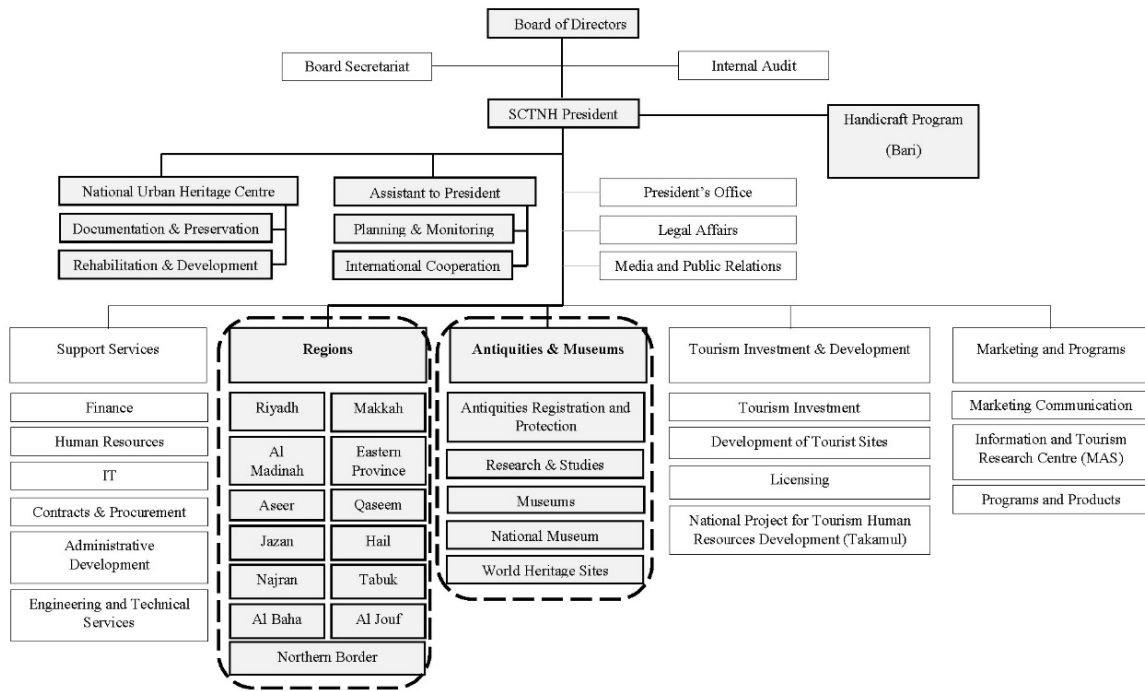

Figure 6. The main players in SCTNH structure (SCTNH, 2018)

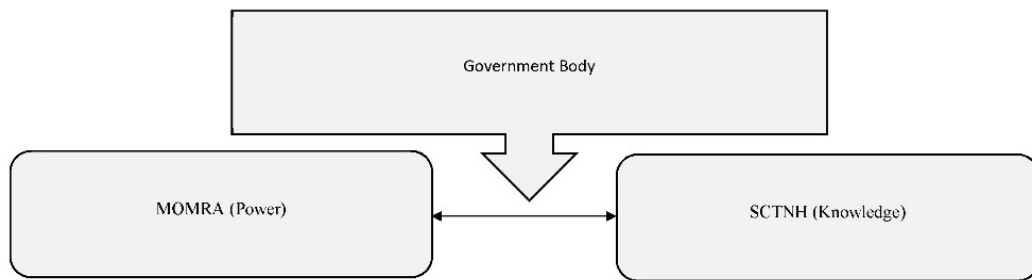

Figure 7. Power, knowledge and new government body

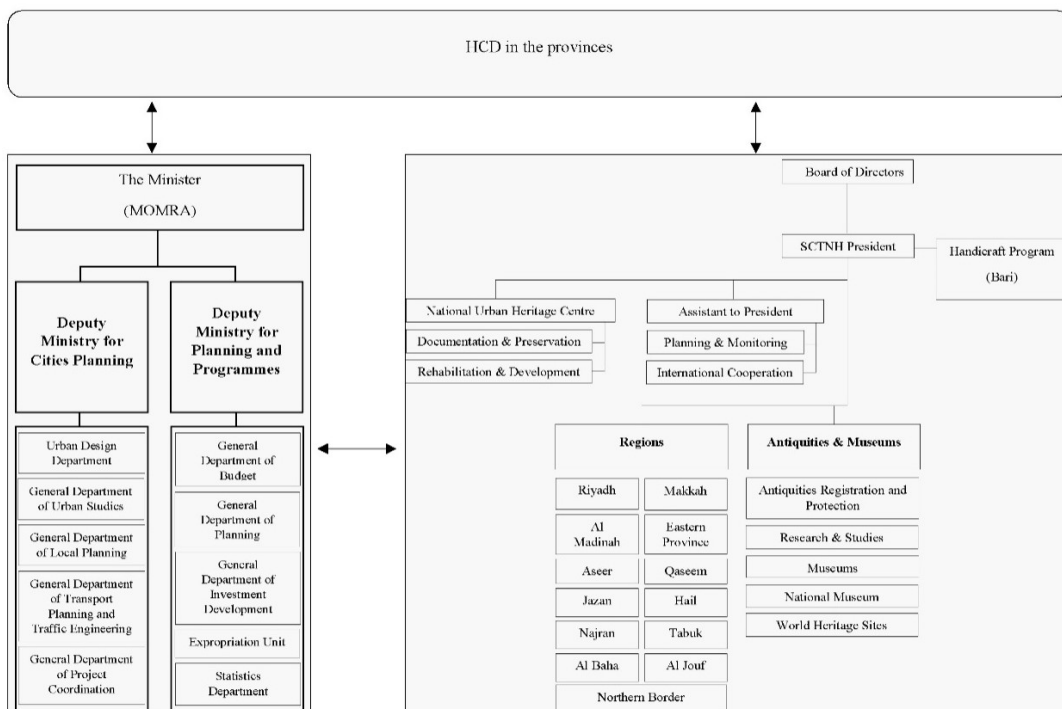

Figure 8. Suggested relationship between major actors in the SCTNH, MOMRA and HCD structures

affairs, including the heritage and folklore general department, the cultural activities general department, and the libraries general department. The media has not given enough attention to cultural heritage, specifically in terms of its contextual value and level of awareness. The lack of coverage on government channels highlights a need for new approaches, which are being addressed by private media channels, including provincial TV channels and various social media accounts related to cities, societies, and cultural heritage. The Public Library, which falls under the responsibility of the MOCI, is a valuable resource for offering knowledge about local cultural heritage. However, there are disconnects between different departments within the MOCI and other external actors, such as the MOE, MOMRA, and SCTNH, that participate in shaping understanding and appreciation of the values of cultural heritage. In 2018, the establishment of the Ministry of Culture (MOC) marked a noteworthy advancement in heritage management. This newly-formed entity now oversees cultural activities, while the former MOCI has been transformed into the MOI.

**Comparative Case Studies:** To gain a deeper understanding of the management and implementation of cultural heritage in the Saudi context, it is important to explore similar experiences in other countries like Egypt. By examining how organizations collaborate in managing historic sites like Cairo, it can provide insights into the improvement of cultural heritage management and implementation. In certain countries like Saudi Arabia, the functions of non-governmental organizations (NGOs) are not well-defined and they face difficulties in operating within government structures. These NGOs do not have a clearly defined role, particularly within government organizations. Adopting a bottom-up approach for heritage management would be more beneficial. Despite the presence of institutional frameworks that involve local contribution and NGO engagement, the degree of local involvement has been insufficient.

**Historic Cairo:** According to Sedky (2009: 32), Historic Cairo demonstrates the significance of heritage management and the importance of collaboration between various groups, including the 'W' (international organizations and concerned individuals), the 'N' (government organisations), and the 'U' (inhabitants and users) groups. The 'N' group of government entities, which includes 10 agencies, are responsible for the development of Historic Cairo. In contrast, the 'U' and 'W' groups have two and three bodies, respectively. However, the size of the group does not matter as much as the concept of the involvement of different actors in cultural heritage development projects. The Cairo governorate is the primary authority in charge of managing, controlling and monitoring urban projects within the city limits. It is noteworthy that the governorate and municipality have been merged into one entity, which may help to reduce conflicts between them, particularly with respect to decision-making. However, despite this consolidation, conflicts are not completely resolved as the majority of the issues and policymaking are still controlled by the governorate, rather than the local municipal agency. This disparity between local and national levels has an impact on heritage management as the distribution of knowledge and power is not balanced. For instance, the ignorance of the architectural and urban characteristics of Historic Cairo by the Governor's Planning Staff can have a negative effect on the other cultural heritage values within the area. Therefore, there is an urgent need to combine knowledge and influence at both local and national levels.

The Saudi Arabian Ministry of Tourism (MOT) is distinct from its Egyptian equivalent. While the Egyptian MOT concentrates on promoting tourism programs and sites, the SCTNH has a wider role due to its responsibility for national heritage. This involves working with municipalities and other players in various ways, such as in regulations, planning, and implementation, which may lead to conflicts within the organization. The Ministry of Culture (MOC), which has 4 divisions working in the project, is another actor in Historic Cairo. The Supreme Council of Antiquities (SCA) is one such division responsible for preserving cultural patrimony and emphasising on archaeological and historical values. However, Sedky

(2009) notes that SCA staff specialize in ancient monuments and antiquities, rather than managing heritage sites, which can be problematic in cultural heritage contexts. At the international level, Egypt has requested assistance from international organizations several times. This collaboration with international organizations emphasizes the importance of community involvement in heritage development, and local players such as heads of the neighbourhood can cooperate with the governorate to resolve municipal issues and coordinate with infrastructure development. The multi-level participation of different players is crucial to prevent conflicts and process repetition.

**Successful experiences in Historic Cairo:** The Egyptian experience emphasizes the significant role of local communities in managing cultural heritage sites through their involvement and empowerment at various levels, including law, policies, planning, development, and implementation. Combining the governorate with the municipality into a single body is a highly effective strategy for managing heritage sites. However, the concern with this approach is that decision-making and problem-solving are centralized in the governorate, which could raise competency issues for staff members. Conflicts related to power and knowledge arise in the management of heritage, particularly when the planning personnel lacks sufficient understanding of architectural patrimony values. While the SCA personnel possess qualifications for handling archaeological sites, they are not equipped for managing heritage sites, and this becomes problematic when they are in charge of heritage management for an extended period. The management of Historic Cairo adopts a multi-player approach with various functions. This approach can be advantageous when considering all actors and their engagement in a holistic plan, which can benefit the players, especially local communities, by allowing them to have a say in improvement plans, particularly during implementation at the local level. However, conflicts between different participants, mainly due to their backgrounds, such as SCA's personnel towards antiquities, present real issues. These challenges can result in some cultural heritage values being prioritized over others. However, some players tackle these challenges by being involved in development plans. The management of urban cultural heritage sites in Historic Cairo and Saudi heritage differ from each other. However, the lessons learned from Egypt should be comprehended and considered by all the Saudi actors involved in cultural heritage development. These practices have highlighted important concepts, such as institutional capability and awareness-building ability. For the Saudi context, it would be advantageous to integrate these approaches in order to develop a new, relevant strategy. This new method should incorporate several parties and combine their authority and experience at the local level, notably under the administrator of the province, with strong involvement from the local public and other stakeholders such as MOMRA, SCTNH, MOCI, and MOE.

**Capability of Institutions:** The tasks of each organization are prioritized and categorized according to their specific functions. In the case of developing a city centre, MOMRA and SCTNH have different approaches. MOMRA prioritizes its administrative and functional responsibilities, such as licensing, municipal services, and investment. Meanwhile, SCTNH considers this development as a prospect to manage and preserve cultural heritage values within the context of the site.

**Awareness Ability:** MOMRA possesses the majority of the heritage places within cities, but it lacks a department dedicated to managing and developing these sites at both the national and local levels. In contrast, SCTNH has a division responsible for managing and developing historic sites, but it has control over them. As Orbasli (2008) notes, having adequate knowledge and expertise of a structure and its framework is essential for making informed decisions in managing urban cultural heritage. The relationship between a building and its context plays a crucial role in this management. To ensure that all necessary expertise is present, it is important to bridge the disparity in knowledge and power between the major stockholders. An initial solution could be to integrate the power and knowledge of both MOMRA and SCTNH to provide a strong foundation so that

other participants may take part in complete plans and management with definite duties and goals. Effective improvement and management of heritage sites requires the integration of knowledge and power (Figure 7), with SCTNH offering the former and MOMRA the latter. Three options exist for achieving this integration, each with its own advantages, disadvantages and challenges. The first option is to establish in MOMRA a national agency, with general departments at the local levels, to develop heritage sites, and transfer personnel from SCTNH to these departments. The second option is to transfer power to SCTNH, but this option may have more challenges than the first. Both options would result in centralised decision-making, potentially delaying progress and limiting creative solutions. The third alternative is to use the notion of sharing, which includes the community and organizations sharing advantages and obligations. This option requires consideration of the heritage requirements, particularly in terms of planning, monitoring, protecting, and improvement, based on their values. Organizational structure can be used to benefit from the components and opportunities of the present state in order to effectively apply the concept of sharing. One way to achieve this is by enhancing the organization of certain authorities, specifically the High Commissions for Development (HCD) of provinces. These commissions operate as autonomous entities under the governance of the provincial governor and have substantial influence at the local level. While each commission has its own set of goals, development management, particularly in urban, social, and cultural domains, is a central responsibility for all of them. The HCD have a specific structure which includes several common departments, including the planning and development and projects management departments (Figure 8). However, there is no department dedicated to managing and developing cultural heritage. To address this, cultural heritage should be included within the common departments of the HCD. By doing this, the organizational structure can bridge the gap among power and knowledge, reducing the distance between MOMRA and SCTNH, who are the major prominent actors in heritage improvement. The aim of connecting MOMRA, SCTNH and HCD is to utilize the expertise and authority of these establishments to benefit both the physical and non-physical aspects of cultural heritage. However, it is important for those who possess the knowledge and resources to be involved in implementing it in the appropriate position within this structure.

**Highlighted matters in heritage management:** The connection between regulations and organizational structure is essential, and cultural heritage must be a primary focus of institutions that manage it and reviewed regularly. For instance, SCTNH's goal is to develop cultural heritage within the tourism sector, but other stakeholders like MOMRA, MOE, and MOCI should also participate in sustainable development, not just in occasional efforts. It is crucial to clarify each organization's responsibilities to avoid conflicts. Cultural heritage, like other service sectors such as economics and health, should be incorporated in national and municipal improvement plans. To ensure the improvement of cultural patrimony in Saudi Arabia, the main stakeholders such as MOMRA, MOE, MOCI and SCTNH should collaborate and integrate the improvement of heritage within their plans at the national and local level. MOMRA and SCTNH play a critical role in this joint development since they possess the essential knowledge and influence required for cultural heritage enhancement. The nature of the interaction between organizations like MOE, MOMRA, and SCTA has a significant impact on the application of policies at the local level. The involvement of administrative stakeholders in an efficient manner highlights the significance of recognizing administrative issues such as autonomy, power imbalances, duplicated processes, and cooperation, which could be potential areas for further exploration in the context of Saudi Arabia.

## CONCLUSION

This study examined the effect of organizational structures on the development of architectural heritage and tourism in Saudi Arabia. The research revealed an absence of structure at national and local levels, leading to a separation of knowledge and power and hindering

the progress of heritage site development. To address this, it is crucial to manage power and knowledge at the local level and involve other actors such as the local community. Establishing relationships with other organizations, such as MOE, MOMRA, and SCTA, is also important for cultural heritage development. The study suggests implementing a unit for managing cultural heritage, led by SCTNH, that promotes sharing and integration. Encouraging stakeholder involvement and public awareness of the cultural heritage value can be achieved by addressing the structure of key players and sharing responsibilities and benefits.

## REFERENCES

- Orbasli, A. (2000) *Tourism in Historic Towns, Urban Conservation and Heritage Management*, London: E & FN Spon.
- Orbasli, A. (2009) The Conservation of Coral Buildings on Saudi Arabia's Northern Red Sea Coast, *Journal of Architectural Conservation*, 15:1, 49-64.
- Orbasli, A. (2008), *Architectural Conservation*, Oxford: Blackwell Science Ltd.
- Historic Cairo, (2002) *Historic Cairo*. Cairo: Supreme Council of Antiquities, Ministry of Culture.
- Sedky, A. (2009) *Living with Heritage in Cairo, Area Conservation in the Arab-Islamic City*, Cairo: The American University in Cairo Press.
- Aldris, A. (2000) *Values included in the citizenship curriculums in the last three classes in primary school in Saudi Arabia*, Riyadh: King Saud University, Faculty of Education, Department of Curriculum and Teaching Methods [in Arabic].
- Abdul Rahman, A. (1982) *History of Education in Makkah*, Jeddah: Dar Alshrouq [in Arabic].
- Hakim, Abdulhamid, H. (2012) *Education System and Policy*, Egypt: Etrak Publish [in Arabic].
- SCT, (2003) *Tourism Development Strategy for Ha'il Province*. Riyadh: SCT
- Ashworth, G. J. and Voodg, H. (1990) *Selling the City: Marketing Approach Approaches in Public Sector Urban Planning*, London: E & FN Spon.
- Ashworth, G.J., Graham, B.J. and Tunbridge J.E. (2007), *Pluralising Pasts: Heritage, Identity and Place in Multicultural Societies* (London: Pluto)
- Barakat, S. & Daher, R. (2000) 'The Cultural Heritage and the Nature of Disasters in Jordan and Palestine', *CRM* 23,6: 39-43.
- Paszucha, M. (1995) *Managing places-Krakow, Historic Cities and Sustainable Tourism*, ICOMOS-UK.
- Larkham, P.J. (1990) 'Conservation and historical townscapes' in T.R.Slater (ed.) *The Built Form of Western Cities*, Leicester: Leicester University Press.
- RTPI - Royal Town Planning Institute (2001). A new vision for planning. [Online] [Accessed on January 29, 2018] <https://www.rtpi.org.uk>.
- Flyvbjerg, B., & Richardson, T. (2002). Planning and Foucault: In search of the dark side of planning theory. In P. Allmendinger, & M. Tewdwr-Jones (Eds.), *Planning futures: New directions for planning theory* (pp. 44–62). London: Routledge.
- Albaqawy, G. (2019) *Architectural Heritage in Saudi Arabia Between Laws, Organizational Structures and Implementation*, PhD Theses, University of Liverpool.
- Larkham, P.J. (1990) 'Conservation and historical townscapes' in T.R. Slater (ed.) *The Built Form of Western Cities*, Leicester: Leicester University Press.
- Flyvbjerg, B., & Richardson, T. (2002). Planning and Foucault: In search of the dark side of planning theory. In P. Allmendinger, & M. Tewdwr-Jones (Eds.), *Planning futures: New directions for planning theory* (pp. 44–62). London: Routledge.