



RESEARCH ARTICLE

IMPLANTABLE ANTENNA FOR BIOMEDICAL APPLICATION

Riboy Cheriyan, Anaswara Sasi, Ashwini Krishna, *Chaithra S. and Princy Elsa Philip

Department of Electronics and Communication Engineering, SAINTGITS College of Engineering, Kottayam, Kerala, India

ARTICLE INFO

Article History:

Received 22nd February, 2017
Received in revised form
04th March, 2017
Accepted 21st April, 2017
Published online 23rd May, 2017

Key words:

Miniaturization,
Upper c band,
HFSS

ABSTRACT

In today's world the demand for biomedical telemetry is increasing day by day. The idea we are putting forward is an 'Implantable antenna for biomedical application'. Miniaturization is the major concern for implantable antennas in biomedical application. The major issue with miniaturization is the degradation of various antenna parameters. In order to meet these limitation several techniques were employed to achieve miniaturization in this paper, viz, reducing the antenna dimension, inducing irregularity in the patch, inclusion of wing and circular patch and addition of Rogers RT-Duroid. In the proposed idea we are evaluating the two different cases of the antenna, one without wing and circular patch and the other with wing and circular patch, using the HFSS software. For biomedical applications the United States Federal communication commission has assigned the MICS band whose frequency ranges from 402-405MHZ. We are using the upper C band for the operation of implantable antenna which is higher than the MICS band in order to increase the bit rate. The resultant antenna has a dimension of 14.64×13.06×0.376[mm]³ with maximum return loss of -34.1db.

Copyright©2017, Riboy Cheriyan et al. This is an open access article distributed under the Creative Commons Attribution License, which permits unrestricted use, distribution, and reproduction in any medium, provided the original work is properly cited.

Citation: Riboy Cheriyan, Anaswara Sasi, Ashwini Krishna, Chaithra S, Princy Elsa Philip, 2017. "Implantable antenna for biomedical application", International Journal of Current Research, 9, (05), 50262-50265.

INTRODUCTION

Implantable antennas are widely used in wireless telemetry applications. After the introduction of implantable pacemakers it has undertaken a drastic change that makes it feasible for use with current technologies especially with the outline of antenna based telemetry (Constantine Balanis, 2005). This implantable device is helpful in diagnosis, monitoring and transmission of patient allied data to nearby base stations. Recently MICS band (402-405MHz) has been assigned which is regulated by the United States Federal Communications Commission (FCC) and the European Radio communications Committee for bi directional biotelemetry operations (Shankar Bhattacharjee et al., 2015). The antenna size should be small enough for implanting. Reducing the size of the antenna has a direct effect on the resonance frequency and several other parameters (Shankar Bhattacharjee et al., 2015). This is due to the change in effective current length path which leads to shifting of the resonant frequency. Several miniaturization tools have been employed earlier like the use of high permittivity dielectric substrate, lengthening of the current flow path on the patch surface, inserting short pins between the ground and the patch plane which upturns the effective size of the antenna, patch stacking technique etc (Constantine Balanis, 2005).

But we are operating the antenna in a higher frequency than MICS band that is in the upper C band (5-8GHz) (FCC, 2002). With the rise in frequency bandwidth also rises which leads to higher bit rate between the implant and the base station (Asimina Kiourti et al., 2012). But with the increase in bandwidth the noise level also increases, which affects the efficiency of the communication channel. So a conciliation between gain and bandwidth has to be achieved in order to have better design.

Antenna design

The design process of the micro strip antenna for biomedical application need some basic parameters fixed such as the height of the substrate, dielectric constant of the substrate and the operating frequency (Constantine Balanis, 2005).

The design equations are used for calculation of length and width of the patch

$$W = \frac{1}{2f_0\sqrt{\mu_0\epsilon_0}} \sqrt{\frac{2}{\epsilon_r+1}} = \frac{c}{2f_0} \sqrt{\frac{2}{\epsilon_r+1}} \dots\dots\dots (1)$$

$$\epsilon_{r_{eff}} = \frac{\epsilon_r+1}{2} + \frac{\epsilon_r-1}{2\sqrt{(1+\frac{12h}{W})}} \dots\dots\dots (1a)$$

$$\Delta L = 0.412 h \frac{(\epsilon_{r_{eff}}+0.3)(\frac{W}{h}+0.264)}{(\epsilon_{r_{eff}}-0.258)(\frac{W}{h}+0.8)} \dots\dots\dots (1b)$$

*Corresponding author: Chaithra S.,
Department of Electronics and Communication Engineering,
SAINTGITS College of Engineering, Kottayam, Kerala, India

$$L = \frac{c}{2f_r \sqrt{\epsilon_{reff}}} - 2\Delta L \dots\dots\dots (2)$$

Where

- W = width of the patch
- C (v_0) = speed of light in vacuum
- f_0 = operating frequency
- μ_0 = free space permeability
- ϵ_0 = free space permittivity
- ϵ_r = srelative permittivity
- ϵ_{reff} = effective permittivity
- ΔL = increase in length
- h = height of the substrate
- L = length of the patch

The equations 1&2 are used to find the width and length of the patch. After finding the effective permittivity, the increase in length is calculated there by calculating the length of the patch

Ground plane:

$$L_g \geq \left(\frac{\lambda}{4}\right) \times 2 + L \dots\dots\dots (3)$$

$$W_g \geq \left(\frac{\lambda}{4}\right) \times 2 + W \dots\dots\dots (4)$$

$$\lambda = \frac{c}{f_r \sqrt{\epsilon_{reff}}} \dots\dots\dots (5)$$

- L_g = Length of the ground plane
- W_g = Width of the ground plane
- λ = Wavelength

By using the equations 3&4 we find the length and breadth of the ground and it is same for the substrate. It will be calculated after finding the value of λ using the equation 5

Proposed antenna

In this paper a C-slotted rectangular microstrip patch antenna is considered. Fig.1 shows the geometry of the first proposed antenna while Fig.2 shows the geometry of the second proposed antenna. The antenna is fed using microstrip feedline connected to a 50Ω impedance (Shankar Bhattacharjee et al., 2015).

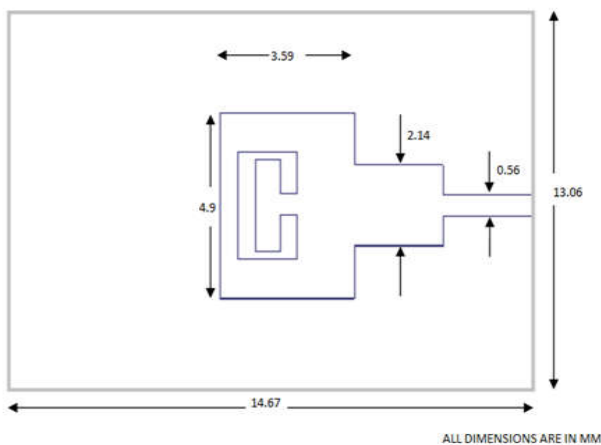

Figure1. Microstrip patch antenna without wing and circular patch

In case 1, a patch antenna of silicon substrate having dielectric constant of 11.9 is used. The patch is made up of gold material and a slot is made over the patch.

Table 1. Dimensions & permittivity of materials used for case1

	Material	Permittivity	Length (mm)	Width (mm)	Height (mm)
Substrate	silicon	11.7	14.64	13.06	h=0.275
Ground	Pec	1	Lg=14.64	Wg=13.06	0.1
Patch	Gold	1	L=4.9	W=3.59	0.05

In the above case the substrate used for antenna has a dimension of 14.64 × 13.06 × 0.275mm³.Silicon substrate is used with a dielectric of 11.7.The material used for ground is the perfect conductor(pec) with dimension 14.64 × 13.06 × 0.1mm³.

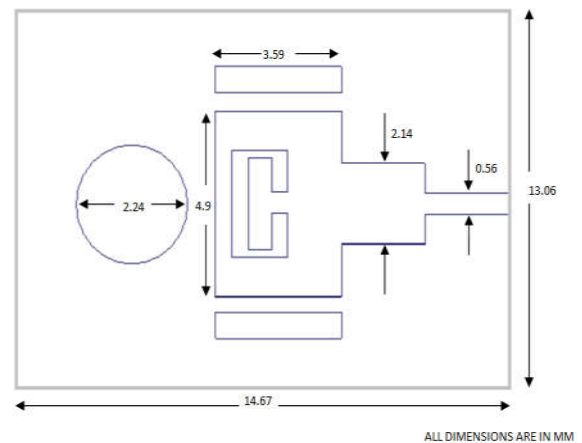

Figure 2. Microstrip patch antenna with wing & circular patch

In the second case all the earlier case configuration are made same. A pair of wing patch and a circular patch is laid over the same plane, adjacent to the main patch as shown in the Figure 2. With the addition of wing and circular patch the length of the effective current path increases and thereby obtaining better return loss.

Table 2. Dimensions & permittivity of materials used for case2

	Material	Permittivity	Length (mm)	Width (mm)	Height (mm)
Substrate	Silicon	11.7	14.64	13.06	0.275
Ground	Pec	1	14.64	13.06	0.1
Patch	Gold	1	4.9	3.59	0.05
Wing patch	Rogers/RT duroid	2.2	3.59	0.7	0
Circular patch	Rogers/RT duroid	2.2	Radius=1.12mm		

Here also a silicon substrate with dimension 14.64 × 13.06 × 0.275mm³ is used. The material used for ground is the perfect conductor (pec) with dimension 14.64 × 13.06 × 0.1mm³.In addition to this we are adding wing and circular patch made of Rogers/RT duroid with dielectric 2.2.The dimension of wing patch is 3.59 × 0.7mm² and circular patch has a radius of 1.12mm.

RESULTS AND DISCUSSION

The designed antenna is stimulated in ANSYS HFSS (high frequency simulation software) software. The results of the two proposed designs were compared and it is then evaluated

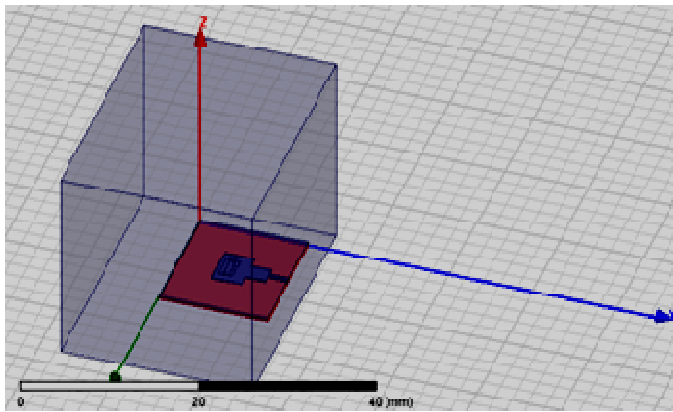

Figure 3. Radiation set up of microstrip patch antenna without wing and circular patch (Case I)

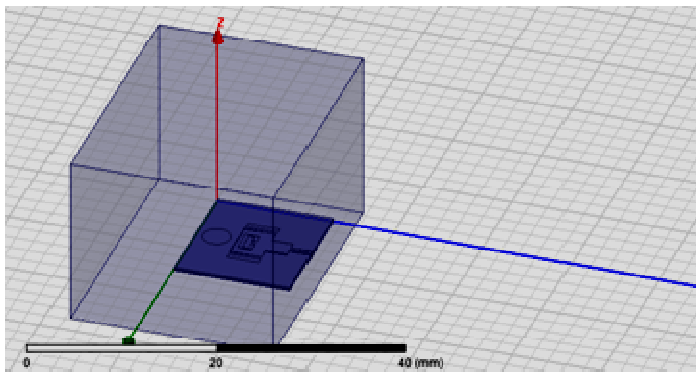

Figure 4. Radiation setup of microstrip patch antenna with wing and circular patch (Case II)

The s_{11} parameter plot an idea about the radiation properties of the antenna. Desirable return loss should be maintained less than -10 db throughout the operating frequency. In our first case the antenna has a maximum return loss of -17.5dB at a resonant frequency of 6.325GHz. In our second case where certain improvement have been made over the first case; It is seen that the antenna has a returning loss of -34.1dB at a resonant frequency of 5.9GHz. In the second case, wing and circular patch lead to the shifting of resonant frequency along with improved return loss due to increase in effective current path[2]. The wing patch and the main patch has no direct connection, but coupled through a capacitance (Shankar Bhattacharjee *et al.*, 2015).

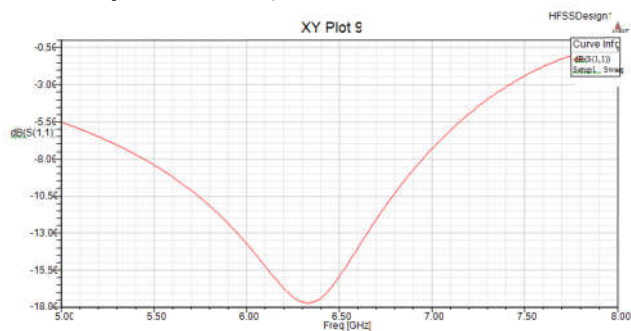

Figure 5. s_{11} parameter of Case I

VSWR is a function of the reflection coefficient which describes the power reflected from the antenna. The VSWR value is always real and positive value for an antenna. In both cases the VSWR value lies between 1 and 2 at the operating frequencies.

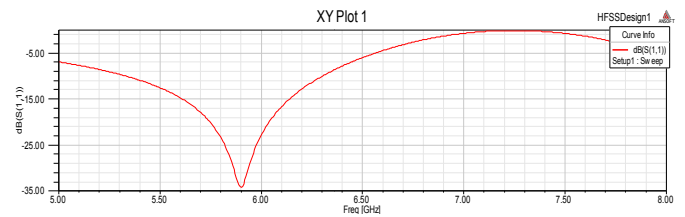

Figure 6. s_{11} parameter of Case II

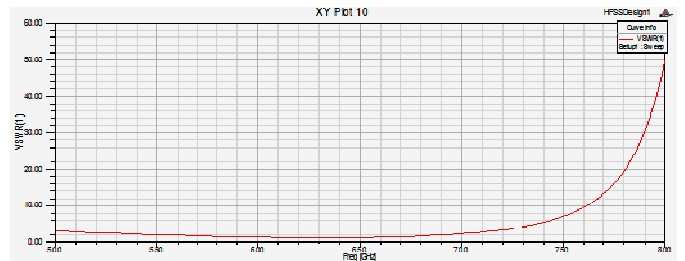

Figure 7. VSWR plot of Case I

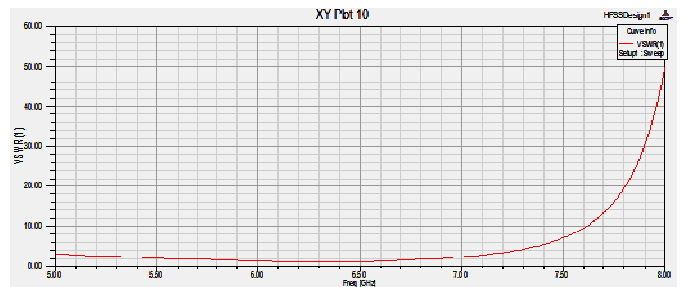

Figure 7. VSWR plot of Case II

An antenna radiation pattern is defined as a mathematical function or a graphical representation of the radiation properties of the antenna as a function of space coordinates. It describes how an antenna directs the energy it radiates and it is determined in the far field region.

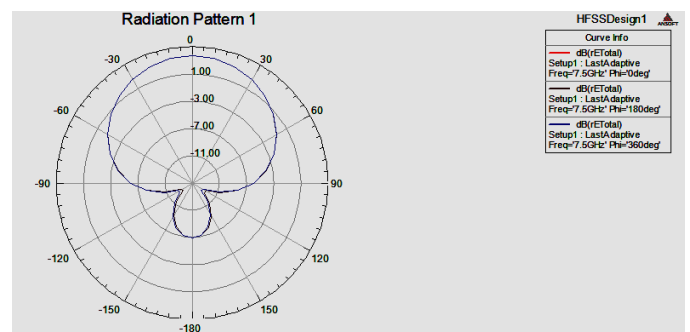

Figure 8. Radiation pattern of Case I

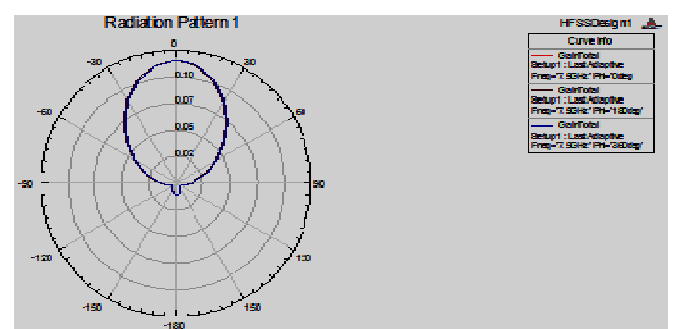

Figure 9. Radiation pattern of Case II

Conclusion

Rectangular microstrip patch antenna with quarter wavelength feedline was designed and simulated in HFSS13.0. Miniaturization techniques employed resulted in the increase of effective current path which in turn reduce the resonant frequency as well as the return loss. The s_{11} parameter for case 1 was found to be -17.5dB at resonant frequency 6.325GHz, while for case 2 it was -34.1dB at 5.9GHz. VSWR for both cases were found to be between 1 & 2. It produces an omnidirectional radiation pattern within the upper c-band range having a bandwidth around 1GHz in both cases.

REFERENCES

- Anders J Johansson, 2004. "Wireless Communication with Medical Implants: Antennas and Propagation", PhD thesis June (2004).
- Asimina Kiourti and Konstantina S. Nikita, 2012. "A Review of Implantable Patch Antennas for Biomedical Telemetry: Challenges and Solutions," IEEE Antennas and Propagation Magazine, Vol. 54, No. 3, June.
- Asimina Kiourti, Jorge R. Costa, Carlos A. 2012. Fernandes, Andr'e G. Santiago, and Konstantina S. Nikita, "Miniature Implantable Antennas for Biomedical Telemetry: From Simulation to Realization," IEEE transactions on biomedical engineering, vol. 59, no. 11, November.
- Constantine Balanis, A. 2005, *Antenna Theory Analysis and Design*, John Wiley & Sons, INC.
- FCC 2002, 'First Report and Order, Revision of Part 15 of the Commission's Rule Regarding Ultra- Wideband Transmission System' pp.2-48.
- Francesco Merli, 2011. "Implantable Antennas for Biomedical Applications", THEISE NO 5110 (2011), PRESENTED le 2 September.
- Pichitpong Soontornpipit, Cynthia M. Furse, and You Chung Chung, 2004. "Design of Implantable Microstrip Antenna for Communication with Medical Implants," IEEE transactions on microwave theory and techniques, vol. 52, no. 8, August.
- Shankar Bhattacharjee, Santanu Maity, Souradip Hore, "Bandwidth Amelioration In Miniaturized Patch Antenna Through Defective Ground Structures for Biomedical Applications", *The International Daily journal*, ISSN 2278 – 5469 EISSN 2278 – 5450, 2015 Discovery Publication.
- Shankar Bhattacharjee, Santanu Maity, Souradip Hore, 2015. "Metamaterial based Micromachined Antenna for Biomedical Applications", *The International Daily journal* ISSN 2278 – 5469 EISSN 2278 – 5450, Discovery Publication.
- Skrivervik, A.K., J.-F.Zurcher, O. Staub and Mosig, 2001. "PCS Antenna Design: The challenge of Miniaturization", IEEE antennas and propagation magazine, vol.43 No.4, August.
